

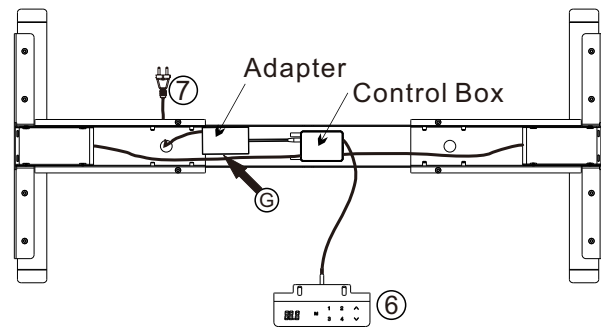

Assembly Instruction



STEP 5:



-Control box is equipped with gyro sensor so the table and control box must be leveled.
-Please fix control box into crossbar so that the desk will work properly.

- Ⓒ Glue Pad * 1
- Ⓔ Control Box Suit * 1
- Ⓕ Handset * 1
- Ⓖ Wires * 3

STEP 6:

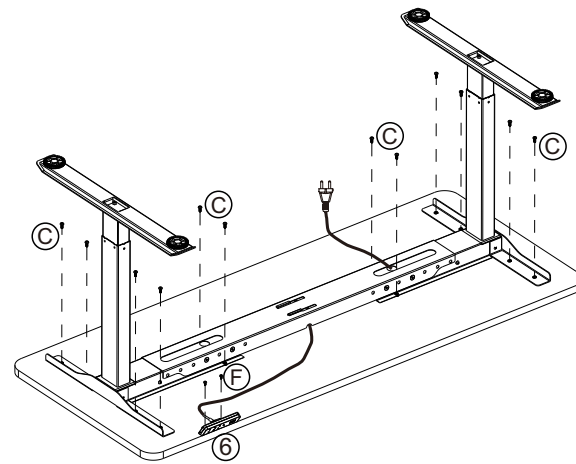

- Ⓕ Handset * 1
- Ⓒ M5×18 Screws * 12
- Ⓕ M4×12 Screws * 2

Ready To Use

Before Plugging the table into the outlet, make sure that

- The lift columns are level and set at the lowest position.
- All the screws are tightened, to avoid the desk making noise and wobbling.

Activate the desk by following the next steps.

- Please press button down and hold for 10-15 seconds until it stutters and beeps.
- Release the button, then your desk is ready to use.

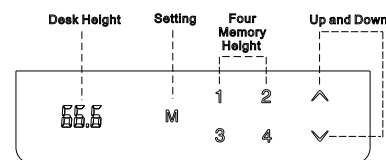

Operation Guide

1. Memory desired height

- Press button "M", display show "S-" with flash.
- Press number and set desired position.

2. Advanced Safety feature- lock and unlock the table.

- Press button up and down at same time for 5 seconds, display "LOC"
- All single button will be inactive and table will be unable to move.
- Pressing button up and down together will unlock the keypad and release the LOC

3. Reset the table

When display show Error code or RST, Please reset the table.

- Unplug the power cord from the control box.
- Unplug the cable that links the keypad to the control box.
- Wait 30 minutes and plug all the cables in again.
- Do the reset: please press button down and hold for 10-15 seconds until it stutters and beeps.

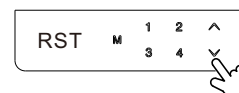
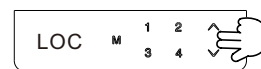
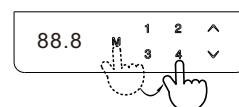

Press by holding 10-15 seconds

If the keypad displays HOT, please unplug and replug and let it cool off for a couple of minutes before proceeding again.

**-Office Desk
-Electric lifting table**

Installation tips



Please don't tighten the screws completely and go back later for a final tightening of all the screws after pieces are aligned with each other .

Lay a mat or used blanket out to assemble onto so the floor and the furniture doesn't get scratched or damaged during installation.

Part List

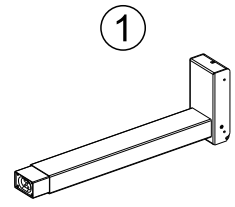

Lift Column *2

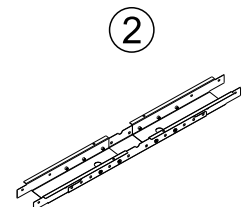

Crossbar End Suit *1

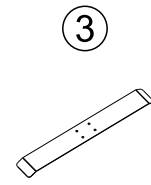

Base *2

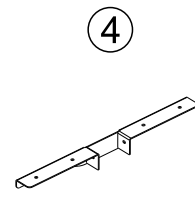

Side Bracket *2

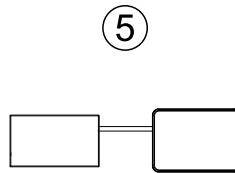

Control Box Suit *1

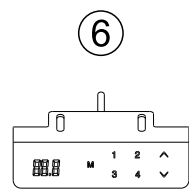

Handset *1

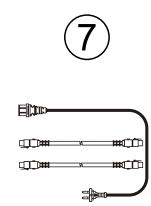

Wires *3

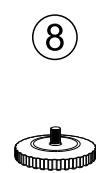

Leveling Studs *4

Accessory Kit

(A)



Qty*8
M6×12
Screws

(B)



Qty*8
M6×16
Screws

(C)



Qty*12
M5×18
Screws

(D)

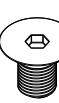

Qty*10
M8×12
Screws

(E)



Qty*12
Washers

(F)



Qty*2
M4×12
Screws

(G)



Qty*2
Cable
Clips

Qty*1
Glue
Pad

(H)



Qty*2
M8
Nut

Tools Required



(H)

+



5mm
Allen Wrench

STEP 1:

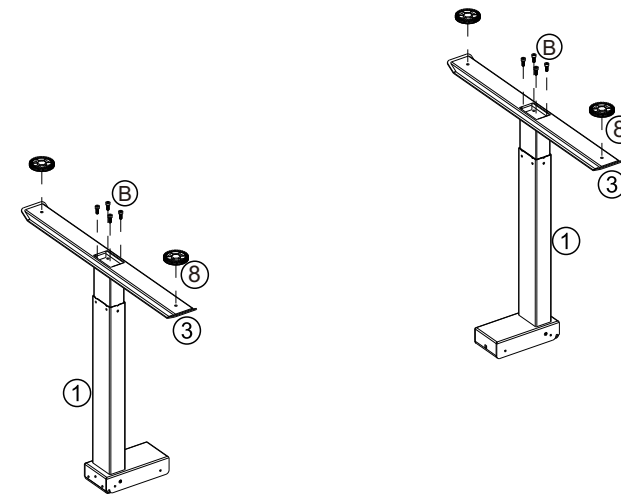

- ① Lift Column * 2
- ③ Base * 2
- ⑧ Leveling Studs * 4
- Ⓑ M6×16 Screws * 8

STEP 2:

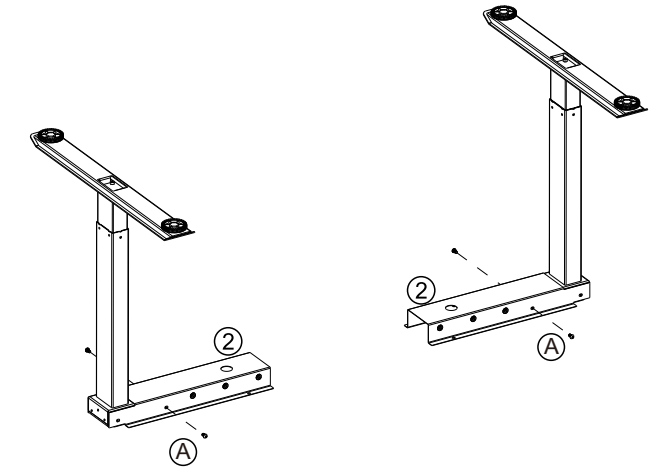

- ② Crossbar End Suit * 1
- Ⓐ M6×12 Screws * 4

STEP 3:

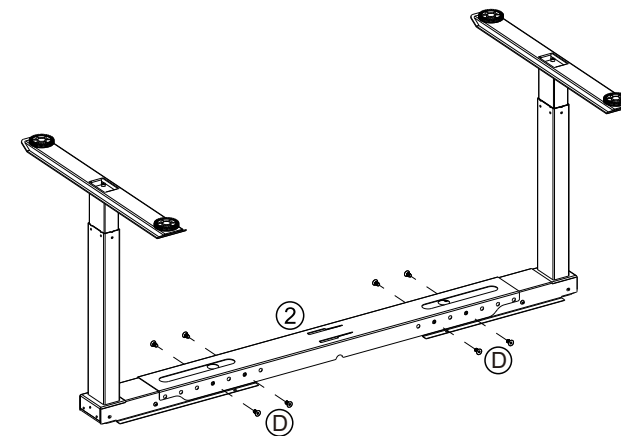

- ② Crossbar End Suit * 1
- Ⓓ M8×12 Screws * 8

STEP 4:

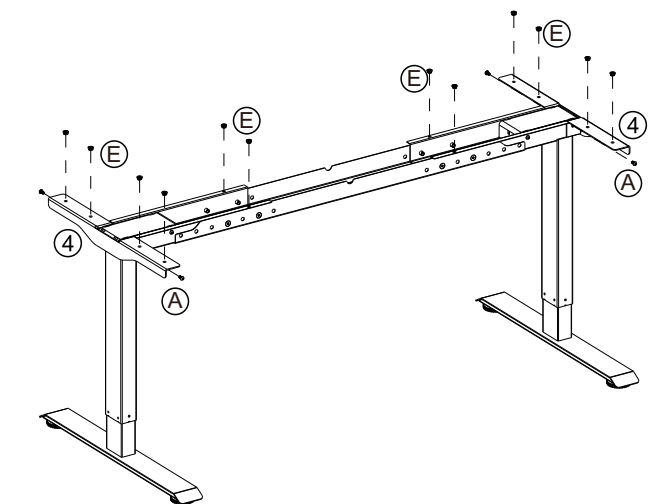

- ④ Side Bracket * 2
- Ⓐ M6×12 Screws * 4
- Ⓔ Washers * 12